

Resettable Switch Call Point Installation Manual

※ Features

- 1.Resettable design,obvious indicators around the edges of the unit.
 - 2.Press the pressing plate to enable the output function.
 - 3.Pressing plate with status (green and red) shown.
 - 4.Reversionary key with non-slip design.
 - 5.Input power range from DC12-24V to connect with all types of fire alarm system.
 - 6.Built-in buzzer status to set as silent, interval wailing or continuous wailing
Volume is adjustable.
 - 7.Easy to assemble, outer case without screws, 3 set of output points to connect other equipment, embedded or surface installations to select.
- Note: only has output point function.

※ Specifications

Item	Model	Parameters		Note
Power supply		DC 12V~DC 24V	×	±5 %
Operation current		DC 12V/18mA(Standby)/75mA(Operation)	×	±5 %
		DC 24V/11mA(Standby)/41mA(Operation)	×	±5 %
Buzzer		Set as silent,interval wailing or continuous wailing	×	
Indicator		Dual-colour (red and green). Red indicator to set blinking , off or on.	×	
Output		N.O. N.C.& COM.Output (Maximum load of 125V/3A)		
Weight		192g		
Dimensions		90mm(L)x93mm(W)x64mm(H)		
Material		ABS,PC(transparent part)		
Relay delay trigger time		1~60s		

※ Accessories

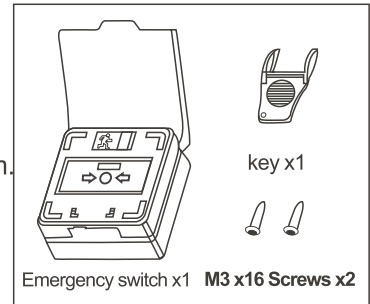

[Standby]

Status display:Green

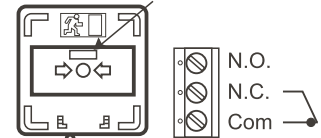

[Operation]

Status display:Red

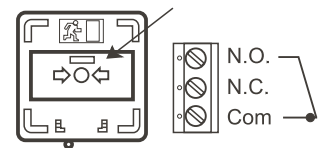

※ Connections

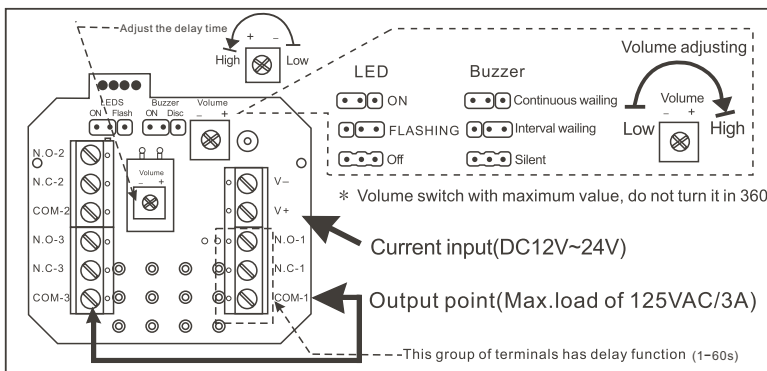

※ Wiring Diagram

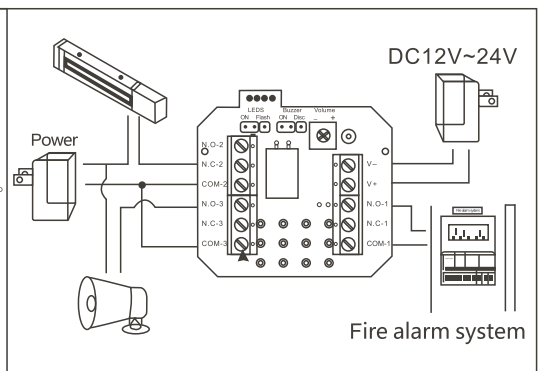

※ Attention before installation

⚠ Please press the pressing plate to make sure the indicator flag turns red before opening the front and middle covers in order to prevent the spring being popped out.

1 Press

2

▲ Fixed holes embedded box as 60mm.

60mm

▲ Restricted terminal's aperture shown below.

φ2.5 1.5

※ Installation

Surface Installation

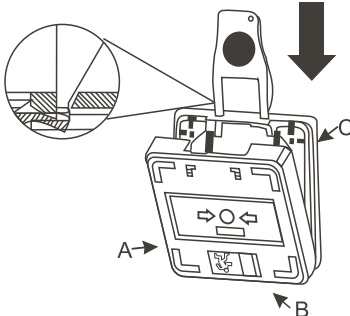
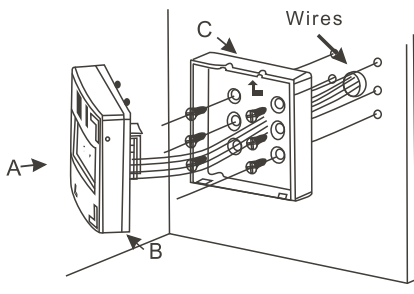
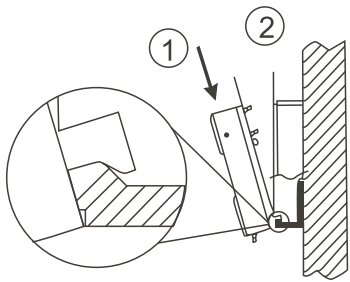
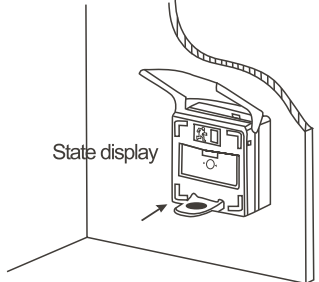
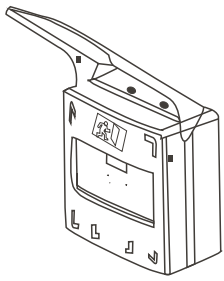
<p>Installation steps</p>	<p>1. </p> <p>Use key to disassemble B and C fastenings.</p> <p>2. </p> <p>Fix bottom cover C and connect the wires</p> <p>3. </p> <p>Fastening the unit as the diagram shown above.</p> <p>4. </p> <p>Insert the key into the key hole. Pull the key out when the flag turns green to complete the setting.</p>
<p>Completed</p> 	

Embedded Installation

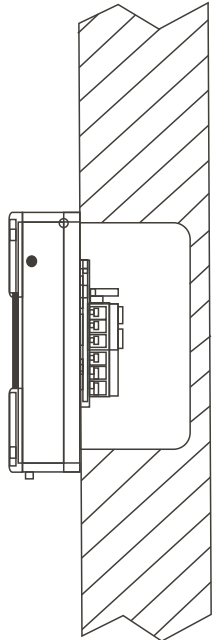
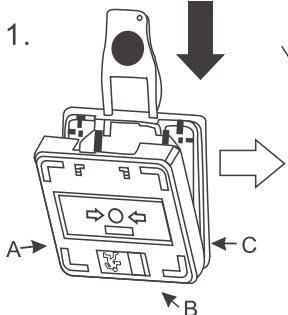
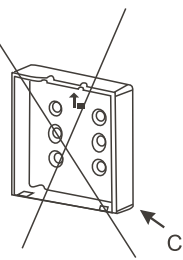
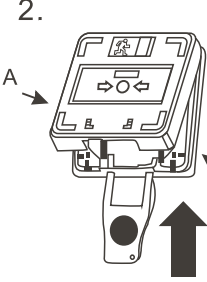
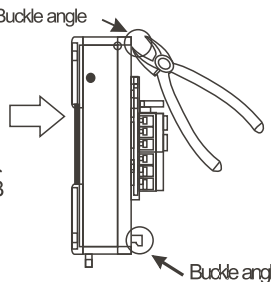
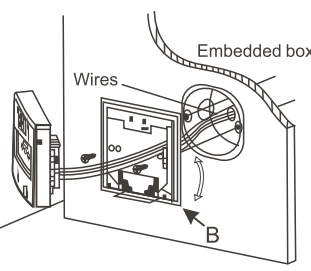
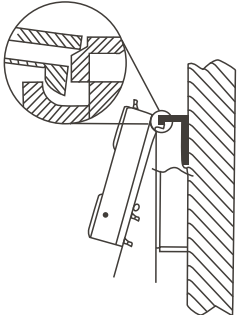
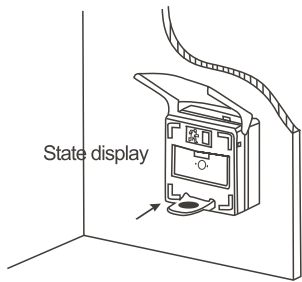
<p>Installation steps</p> <p>Lateral view</p> 	<p>1. </p> <p>Use key to disassemble B and C fastenings.</p> <p></p> <p>No bottom cover C needed for embedded installation.</p> <p>2. </p> <p>Use key to disassemble A and B fastenings.</p> <p></p> <p>Clip the unnecessary buckle angles.</p> <p>3. </p> <p>Fix middle cover B and connect the wires.</p> <p>4. </p> <p>Fastening the unit as the diagram shown above.</p> <p>5. </p> <p>Insert the key into the key hole. Pull the key out when the flag turns green to complete the setting.</p>
---	---